

TECHNICAL DATA SHEET - Vision•Point™ Articulating Wall Arm/ Cabinet Side Mount for LCD screens



MODEL: LCL
Patent Pending.

The sleek aluminum design of this mount makes it the perfect mounting solution on a wall, on the side of a bathroom or kitchen cabinet, around a corner, or anywhere full articulation and superior adjustment features are needed. With a three-link design, articulation at three pivot points and a ball/joint at the screen for additional side-to-side and up/down movement, the screen can swing all the way around the side of a cabinet or around a corner to be viewed from the other side of the room. In addition, the arm completely collapses against the wall when not in use and virtually disappears behind the screen when folded. The LCL models are designed for LCD screens over 15" in width and weighing up to 25 lb. All models come fully kitted.

Features:

- Color: Clear Anodized aluminum
- Designed for LCD screen over 15" in total width and up to 25lb*
- Fully articulating at three pivot points
- Ball/joint design at screen for additional side-to-side and upward and downward tilt
- Offers 180° of swivel on a wall; up to 270° of swivel around the side of a cabinet or around a corner*
- Features 70° (±35°) of upward and downward tilt
- Ball/joint tension is set at time of installation— all around movement is obtained by simply moving the screen
- Folds completely flat against the wall
- Sleek aesthetics neatly enhances any LCD screen
- External cord management through cord clips provided
- 22 ¾" long when fully extended
- Supports screens with VESA® 75 or 100 mounting holes
- Several kitted models also available for screens with non-VESA hole patterns
- Comes with hardware for installation to the side of a cabinet, and to wood stud or concrete

Accessories:

- Metal stud wall accessory kit - ACC 908

* Offers full 270° of swivel capability around a cabinet or corner for screens 15" to 20" in width (swivel may be slightly restricted with wider screens)

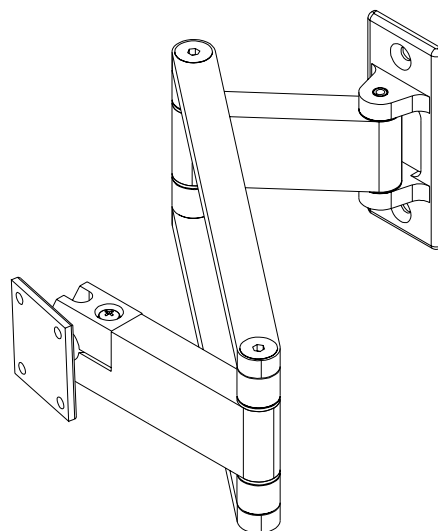

Dimensions:

Weight:

2.53 lb (1.2kg)

Shipping weight:

4.19 lb (1.9 kg)

Maximum Load Capacity:

25 lb (11.4 kg)

Shipping Carton dimensions:

L = 12.8 in (325 mm)

W = 9.5 in (241 mm)

H = 2.5 in (64 mm)

ARCHITECTS SPECIFICATIONS

The Articulating Wall Arm shall be a Peerless model **LCL** and shall be located where indicated on the plans. Assembly and installation shall be done according to instructions provided by the manufacturer. Mount is made of anodized aluminum and adapter is made of steel with a scratch resistant epoxy silver finish.

TECHNICAL DATA SHEET

MODEL: LCL
Patent Pending.

